

# CR Series Dual Control Valves For Hot Water Space Heating And Boilers

## DESCRIPTION

The Cash Acme CR Dual Control Valve for hot water space heating is designed for a variety of installations. It is suitable for one, two or three story buildings without adjustment.

The Cash Acme CR Dual Control Valve has an iron body, brass internal parts on regulator section, special heat resistant composition diaphragm and O-rings, brass strainer screen and stainless steel springs. Relief valve has a bronze body, silicone seat disc and stainless steel spring. The CR Valve is available in a 1/2" size only.

The Cash Acme CR Dual Control Valve features a balanced piston for closer outlet pressure control regardless of variations in inlet pressure and a rapid fill feature with an improved larger seat for higher capacities and quicker fill.

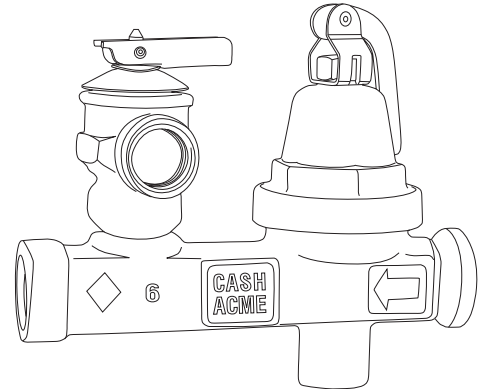

## FEATURES AND BENEFITS

Poppet relief design:

*Provides over-pressure protection.*

Every valve is tested for performance prior to shipping:

*Specify and install with confidence!*

Economical and exclusive design features:

*Saves time and money!*

# CR Series Dual Control Valves For Hot Water Space Heating And Boilers

## TYPICAL INSTALLATION

The **Cash Acme CR Dual Control Valve** should be installed as close as possible to the top of the boiler and the cold water supply line connected to the inlet or regulator side of the valve. Incoming pressure enters the regulator and is reduced to the current operating pressure of the system, 14 psi.

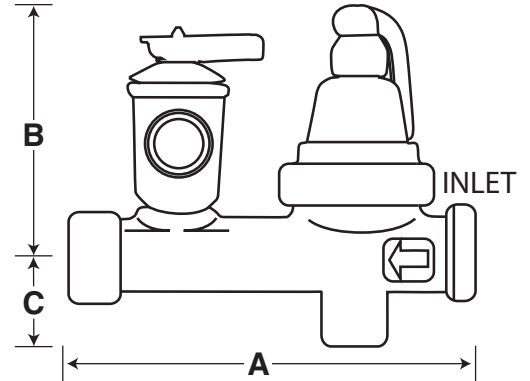
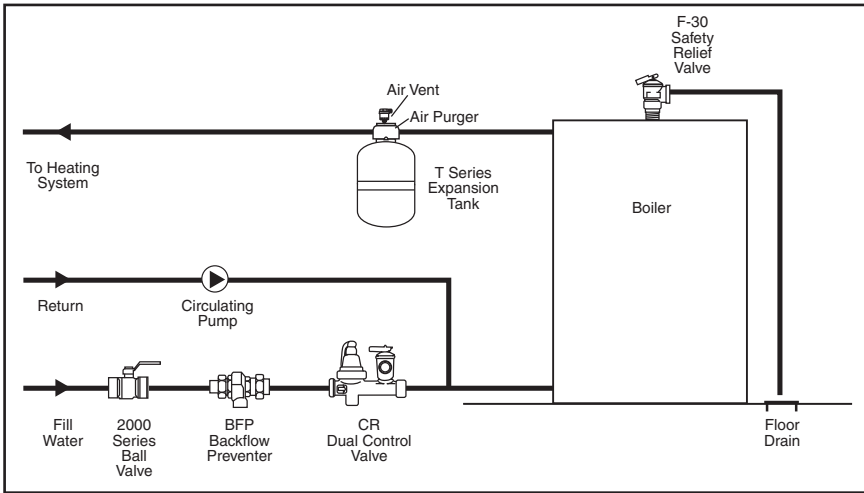

Dimensions	A	B	C
1/2" Threaded (NPT)	6-3/16"	3-25/32"	1-7/16"

## SPECIFICATION DATA

### Performance:

Outlet pressure . . . . . Factory set at 14 psi  
 Maximum temperature . . . . . 180°F  
 Maximum inlet pressure . . . . . 100 psi  
 Service . . . . . Water

### Materials:

Body . . . . . Iron  
 Strainer . . . . . Brass  
 Springs . . . . . Stainless steel  
 O-rings . . . . . EP  
 Diaphragm . . . . . Buna-N/Nylon

## CONNECTIONS

Threaded (NPT) . . . . . 1/2" Inlet, Outlet  
 Sweat . . . . . 1/2" Inlet