

In-Line Check Valve

DESCRIPTION

The Cash Acme In-Line Check Valve is a NSF-61 certified general purpose, spring loaded Check Valve that prevents the reverse flow of water, oils and other fluids. Unlike the metal to metal check valves, the Cash Acme Check Valve combines a spring loaded design with NBR seat to create a fast seating and bubble tight shut-off. The Cash Acme In-Line Check Valve cost effective design offers a low cracking pressure of 1/2" PSI and a flow profile to minimize head.

The Cash Acme Check Valve is center guided with four secondary external machined guides that prevents side loading.

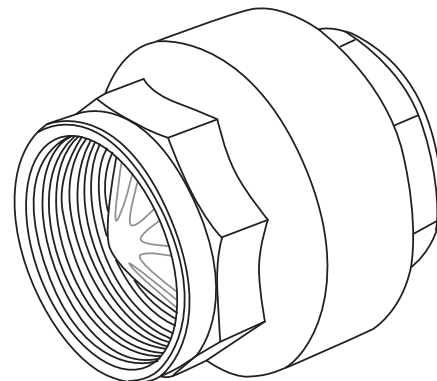

FEATURES AND BENEFITS

NSF-61 certified for domestic water service:
Inspector friendly, peace of mind.

NBR Seat:
Creates a fast and bubble tight shutoff

More Flow:
Flow profile designed to minimize head loss.

High technology materials:
To ensure best resistance in any conditions.

Perfect sealing:
At high and low pressure.

Secondary External Guides:
Increase performance, longevity and prevents side loading of seat.

CERTIFICATIONS

The Cash Acme In-Line Check Valve is NSF-61 certified.

In-Line Check Valve

TYPICAL INSTALLATION

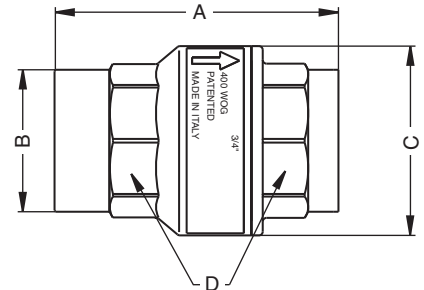
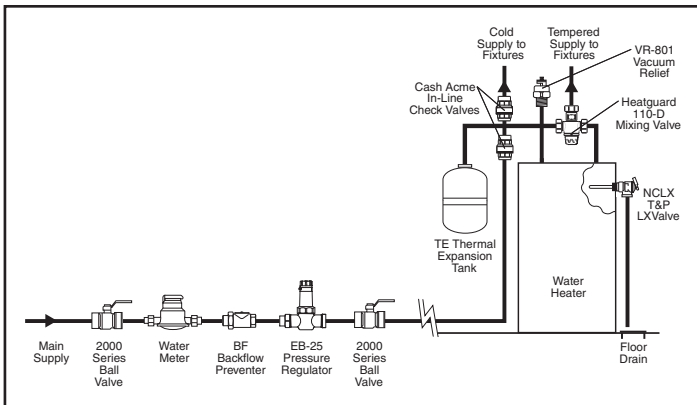

SIZE	A	B	C	D
3/8"	2.32	.98	1.35	.98
1/2"	2.32	.98	1.35	.98
3/4"	2.56	1.20	1.65	1.22
1"	2.76	1.48	1.92	1.50
1 1/4"	2.93	1.87	2.40	1.89
1 1/2"	3.17	2.10	2.87	2.12
2"	3.37	2.68	3.46	2.64

SPECIFICATION DATA

Performance:

- Maximum temperature 210°F
- Maximum pressure 400 psi (3/8"-2")
- Service Water, oil, general purpose
- Minimum cracking pressure 1/2 psi

Materials:

- Body Brass
- End Connection Brass
- Check module Polyethereimide
- Seat NBR
- Spring Steel

CONNECTIONS

- Threaded (NPT) 3/8" through 2"